

13HPE SD SAIL DRIVE MARINE ENGINE

Models: 80



RELIABLE AND LONG-LASTING

FNM® 4-cylinder 13HPE marine engine is built according 1,3 Multijet II features, a key product for small diesel engines in automotive industry. The engine uses a common-rail fuel injection system controlled by an electronic control unit developed in house, made specifically for this unit. The result is a high power-to-displacement ratio unit.

HIGH LEVEL PERFORMANCES

Set either for recreational use, where the engine reaches up to 81kW (110HP), or for any commercial purpose, where it can achieve up to 3000h/year, this unit guarantees excellent performances at each kind of operating condition.

ECU DEVELOPED IN HOUSE

The engine electronic control unit (ECU) has been conceived after a 10-year development project carried out by R&D team; it is especially designed for HPE marine engines application. The ECU controls common rail system parts and included unique control strategies which can be personalized according customers' request. It guarantees excellent performances with limited emissions.

TECHNICAL DATA

Engine designation	13 HPE 80
Crankshaft Power [kW] (hp)	59 (80)
Propeller shaft power [kW] (hp)	57 (78)
Engine speed [min ⁻¹]	3800
Displacement [l] (in ³)	1,3 (76)
Number of cylinders	4
Bore/stroke [mm] (in)	69,6/82 (2,74/3,23)
Compression ratio	17,6:1
Dry weight with Sail Drive [kg]	220
Power Rating	C
Emission compliance	RCD Stage II 2013/53/UE

PERFORMANCE CURVES

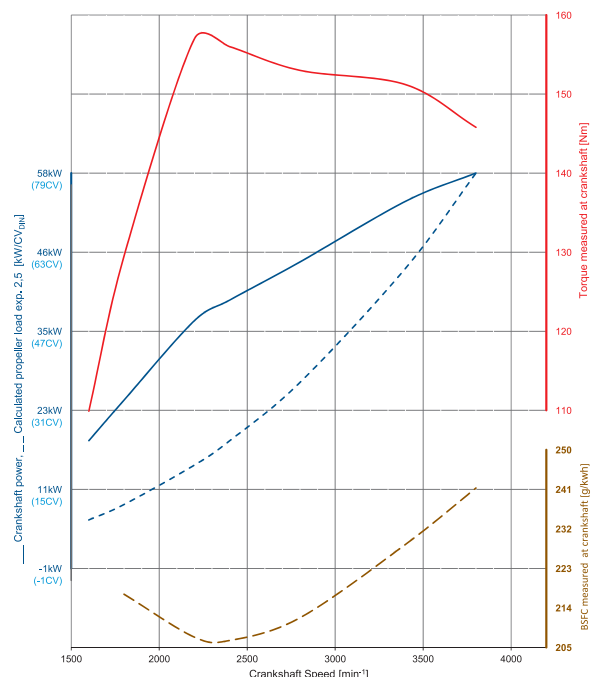

Engine shown in the picture could be not equal to standard engines

Referred to 13HPE SD 80

Technical data according ISO8665, fuel according EN590 standards. Fuel available on the market could have different specifications, influencing engine's power and consumptions. Production tolerance within 5% (on power). Not all produced models, equipments and accessories could be available in all countries.

TECHNICAL CHARACTERISTICS

ENGINE BLOCK AND HEAD

- Cylinder block made of cast-iron
- Cylinder head made of aluminium
- 4-valve per cylinder technology with hydraulic lash adjusters
- Double overhead camshafts
- Automotive-class availability of service and parts
- Metal chain gear

LUBRICATION SYSTEM

- Easily replaceable oil filter, on top of engine
- Easily to inspect or replace oil separator
- Oil vapour filter
- Integrated cooler with engine's coolant

FUEL SYSTEM

- Common rail fuel injection system
- CMD proprietary ECU
- Fuel filter with water separator and alarm

AIR INLET AND EXHAUST SYSTEM

- Air filter
- Oil vapours vented into inlet air
- Exhaust elbow or raiser depending on application
- Variable geometry turbocharger
- Raw-water cooled intercooler

COOLING SYSTEM

- Thermostatically regulated freshwater cooling
- Thermal unit that integrates tubular heat exchanger and expansion tank
- Easily accessible seawater impeller pump

ELECTRICAL SYSTEM

- 12V standard two-pole electrical system
- 12V-1,3kW starter
- Alternator 12V-75A
- Emergency stop button on engine's ECU
- CANBUS Panel with 8m extension and digital display of engine data

ENGINE MOUNTING

- Flexible engine mounting

PANEL INSTRUMENT CANBUS

Panel Instrument high brightness 5 "TFT display, with touchscreen and a very simple and intuitive interface and offers the following features:

- Engine data acquisition with CANBUS J1939 interface.
- Data acquisition from traditional sensors for up to eight analog inputs, five digital inputs and one frequency input.
- Acquisition of navigation data with NMEA0183 interface.
- Up to five relay command outputs for signals and simple activations.
- Alarm monitoring according to approved safety standards.
- Automatic brightness adjustment and day / night mode.
- USB local connectivity for firmware update and configuration.



The unit is supplied already programmed and ready to work.

DIMENSIONAL FNM 13HPE SP with SEADROP 60

Side view

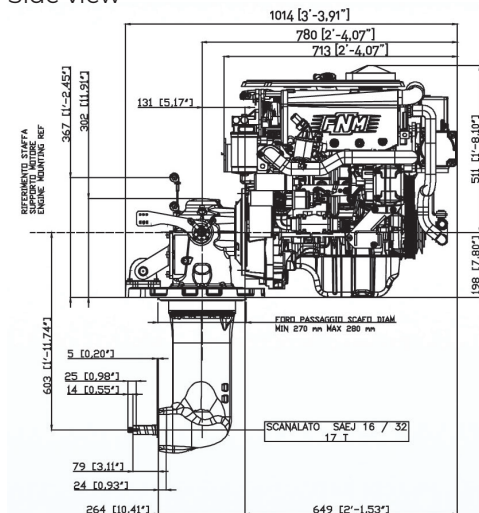

Rear view

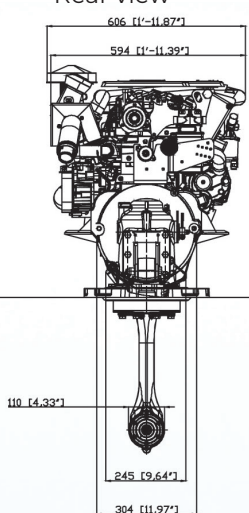

Top view

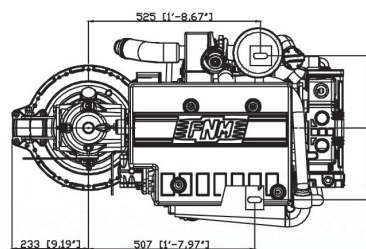

OPTIONALS

- Spinner for fixed blade propellers
- VTR Tecnodrive engine base
- Boats template
- Single or double electronic CANBUS control station
- Boiler kit for heating
- Various length panel extension
- Second control panel for flybridge installations
- RACOR and Mediterraneo filters
- 90A alternator
- Wide range of additional instruments
- Flange for application without VTR base
- Water Sensor



Find out our dealers using our QR code or call +39 393 9092265 for further informations



FNM Marine Diesel Engines
it's a brand
CMD a Loncin Company

Nucleo Industriale · Valle di Vitalba · 85020 · Atella (Pz) · Italia
Tel. (+39) 0972 715757 · support@fnm-marine.it · www.fnm-marine.it

